



Stacking Instructions



Stacking option can be used for models 301, 301P and 302. For models 301 and 302, you must have at least 2 units on top and units on bottom to be able to securely stack. For the model 301P, you must have at least 3 units on top and 3 units on model to be able to securely stack.

If at any time you have any questions or concerns please contact the Manufacturer

American Bicycle Security Company

P.O. Box 7359

Ventura, CA 93006

Ph: (800) 245-3723 or (805) 933-3688

Fax: (805) 933-1865

www.ameribike.com

Email: turtle@ameribike.com

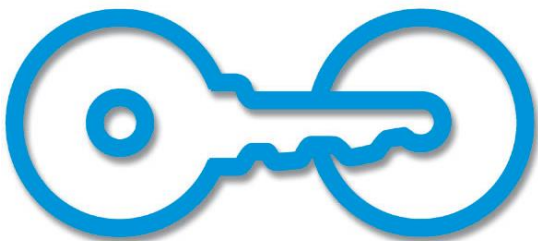

EFFECTIVE:

9/30/14

Stacking Instructions



Hardware included:	Quantity
1/4" – 20 x 1" Carriage Bolts	6 per unit
1/4" – 20 Hex Nuts	6 per unit
1/4" Flat Washers	6 per unit

Tools needed:

Drill
1/4" Drill Bit
7/16" Wrench

1. Before starting this step you should have all of your ground level lockers anchored and bolted together so they do not move or change door alignment.
2. With 2 or more people, starting at one end of the grouping of lockers, lift the first unit in place and set on top of the ground level locker. Position the upper unit so that it lines up with the locker unit. With this done, you will now need to drill 1/4" holes through the base flange in the upper units and through the roof of the ground level units. See diagram below for general locations.
 - We recommend following the sequence of drilling and bolting as indicated in the diagram so that the upper unit does not shift during the drilling process. Carriage bolts should be installed downward through the flange and locker top. Washers and nuts will be inside the ground level lockers. Tighten the nuts so they are snug.
3. Continue this process with each of the upper units.

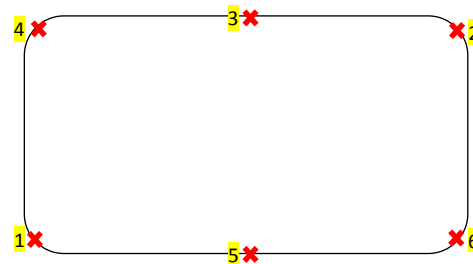
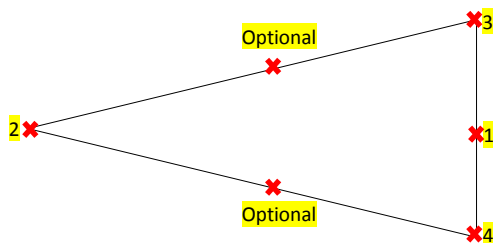

✕: Indicated approximate anchor locations
1-8: Recommended sequence for drilling

If at any time you have any questions or concerns please contact the Manufacturer

American Bicycle Security Company

P.O. Box 7359

Ventura, CA 93006

Ph: (800) 245-3723 or (805) 933-3688

Fax: (805) 933-1865

www.ameribike.com

Email: turtle@ameribike.com

EFFECTIVE:

9/30/14

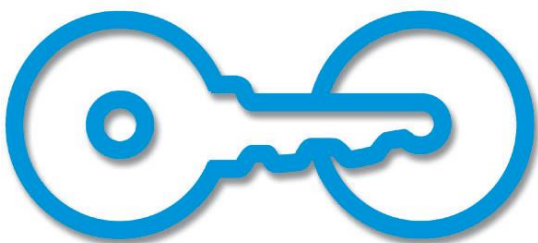

Stacking Instructions



Stacking Heights

Recommended Clearance from doors: 5'

Model 301

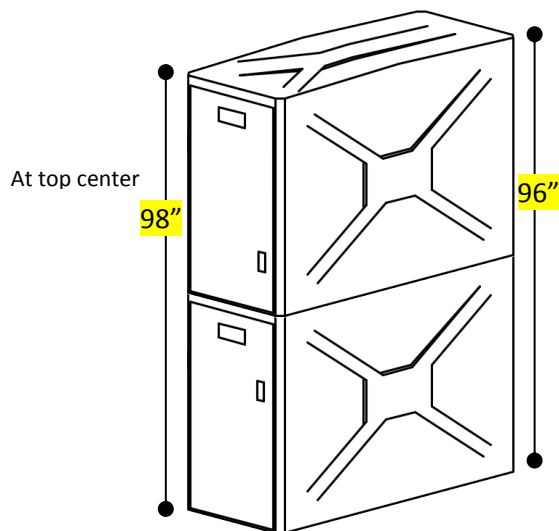

Model 302

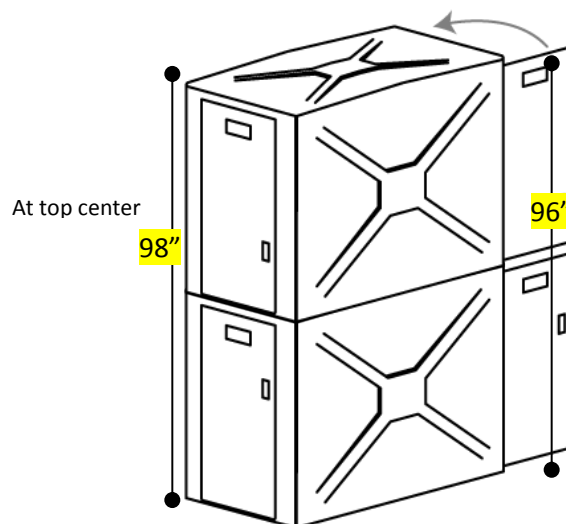

Model 301P

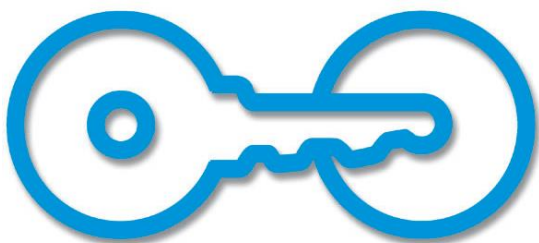
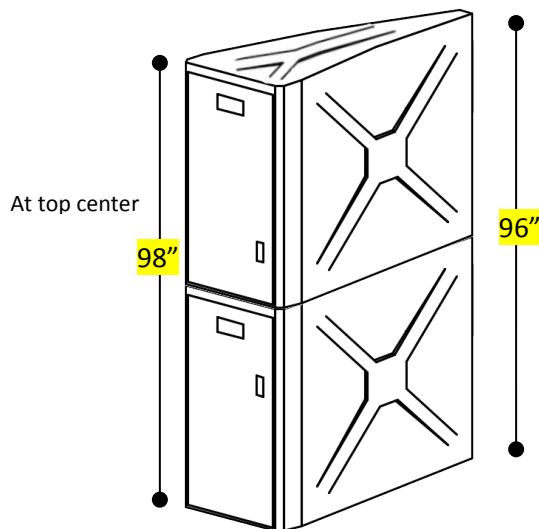

EFFECTIVE:

9/30/14

American Bicycle Security Company

P.O. Box 7359

Ventura, CA 93006

Ph: (800) 245-3723 or (805) 933-3688

Fax: (805) 933-1865

www.ameribike.com

Email: turtle@ameribike.com