

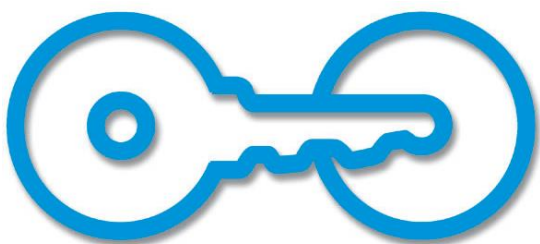

# Air Kit Prime



**American Bicycle Security Company**

P.O. Box 7359

Ventura, CA 93006

Ph: (800) 245-3723 or (805) 933-3688

Fax: (805) 933-1865

[www.ameribike.com](http://www.ameribike.com)

Email: [turtle@ameribike.com](mailto:turtle@ameribike.com)

# Air Kit Prime

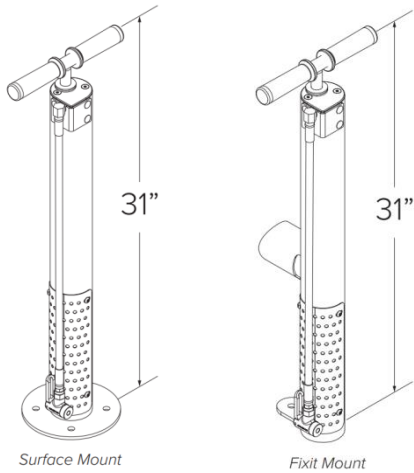

**Product** Air Kit Prime

**Materials** Main Body: 3" x 1/8" steel tube  
Manual air pump: max. 100psi  
Foot: 1/4" steel

**Finishes** Standard options: Galvanized  
Powder Coated



RAL 9005	Flat Black	RAL 9003	RAL 2004	RAL 1023	Bright Yellow
RAL 6016	RAL 6018	RAL 6005	RAL 3003	RAL 3005	Purple
RAL 7011	RAL 7042	RAL 9007	RAL 1001	RAL 8014	Bronze

Also available in Stainless Steel upon request.

**Installation Methods** **Surface Mount** has 7" diameter x .25" flange with four anchoring holes for mounting with standard wedge anchors.

**Fixit Mount** attaches to side of Fixit bike repair station

**Space Use & Setbacks** At least 36" from any obstruction.

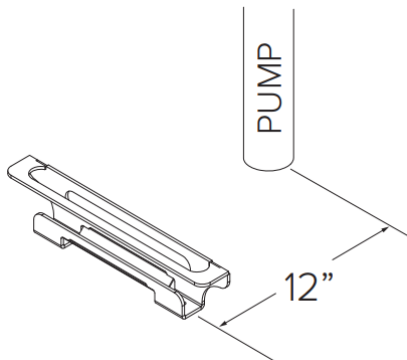

An optional wheel catch is also available to hold bikes with no kick stands

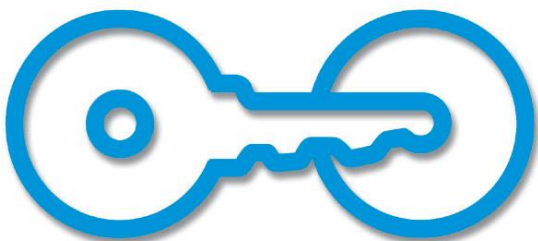
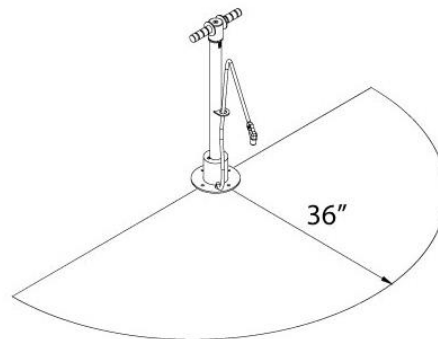

## American Bicycle Security Company

P.O. Box 7359  
Ventura, CA 93006  
Ph: (800) 245-3723 or (805) 933-3688  
Fax: (805) 933-1865  
www.ameribike.com  
Email: turtle@ameribike.com

# Air Kit Prime

Installation instructions:  
Surface Mount



## Tools Needed for Installation

- Marker or Pencil
- Masonry Drill Bit 3/8"
- Drill (Hammer drill recommended)
- Hammer
- Wrench 9/16"
- Level

## Recommended Base Materials:

Solid concrete is the best base material for installation. To ensure the proper anchors are shipped with your Air Kit, ask which anchor is appropriate for your application. Be sure nothing is underneath the base material that could be damaged by drilling.



1

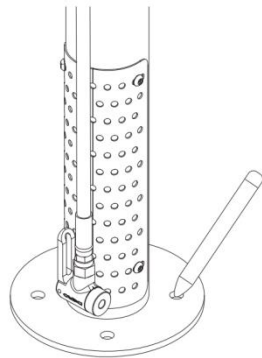

Place the Air Kit Prime in the desired location. Use a marker or pencil to outline the holes of the flange onto the base material.

2

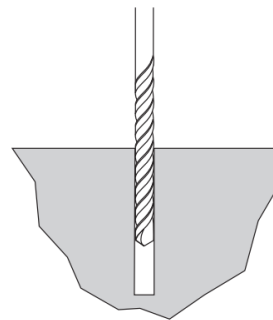

Drill the holes in accordance with the specifications shipped with the anchors. Make sure the holes are at least 3" away from any cracks in the base material.

3

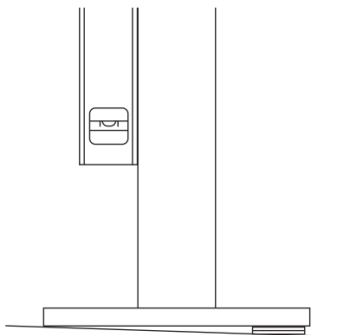

Use washers to level pump if necessary.

4

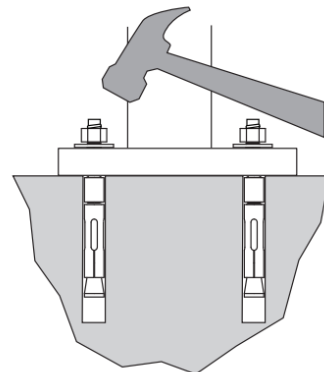

Thread nuts onto anchors, leaving approximately 1/4" of the anchor protruding, and tap into surface. **Place the 2 provided tamper-proof penta nuts on opposite sides.** Tighten nuts down to secure pump.

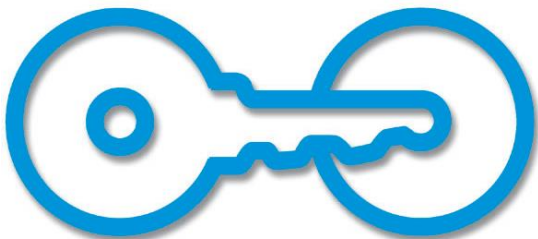

**American Bicycle Security Company**

P.O. Box 7359

Ventura, CA 93006

Ph: (800) 245-3723 or (805) 933-3688

Fax: (805) 933-1865

[www.ameribike.com](http://www.ameribike.com)

Email: [turtle@ameribike.com](mailto:turtle@ameribike.com)

# Air Kit Prime

Installation instructions:  
Fix It Mount



1

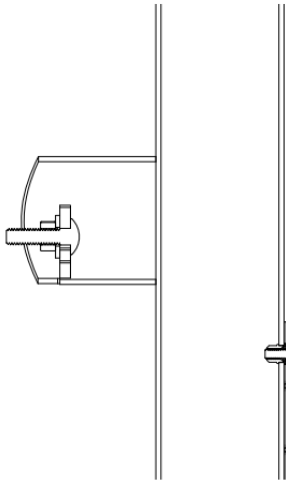

Firmly attach the carriage bolt to the pump with the nut and washer.

2

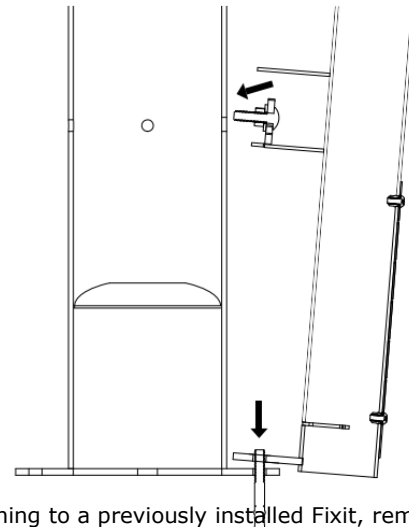

If attaching to a previously installed Fixit, remove the nut and washer on the wedge anchor on the side of the Fixit to receive the pump. Place the pump lower flange hole over the wedge anchor, and slot the previously attached carriage bolt through the hole on the side of the Fixit.

3

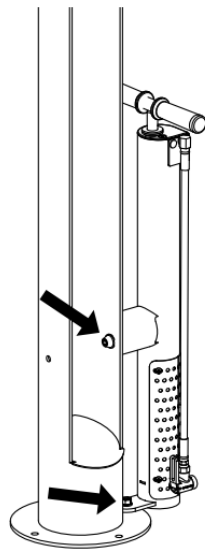

Loosely secure the carriage bolt with a rubber-backed washer and tamper-proof nut in the inside of the Fixit.

Use the wedge anchor washer and nut to secure the pump flange and then tighten the tamper-proof nut inside the Fixit.

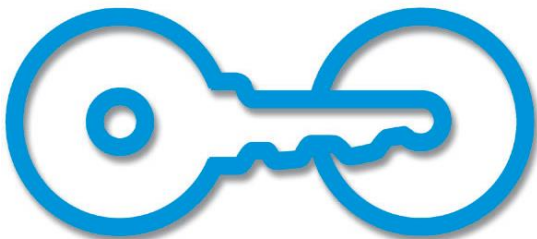

**American Bicycle Security Company**

P.O. Box 7359

Ventura, CA 93006

Ph: (800) 245-3723 or (805) 933-3688

Fax: (805) 933-1865

[www.ameribike.com](http://www.ameribike.com)

Email: [turtle@ameribike.com](mailto:turtle@ameribike.com)



1

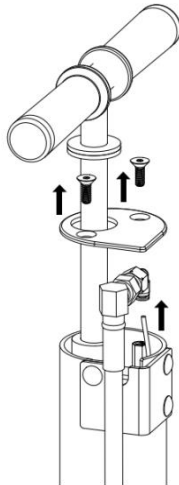

Remove the 2 tamper-proof screws at the top of the pump and lift the cap. Then disconnect the airline via the push-to connect fitting at the top of the hose.

2



Slide the pump sideways out of the main body slot and then lift the whole pump and air lines out of the main body

3

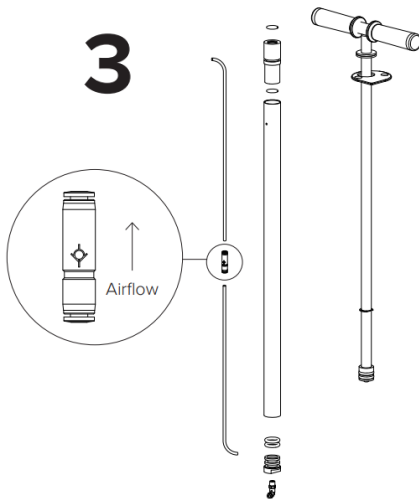

The pump can now be taken apart without tools for servicing.

4

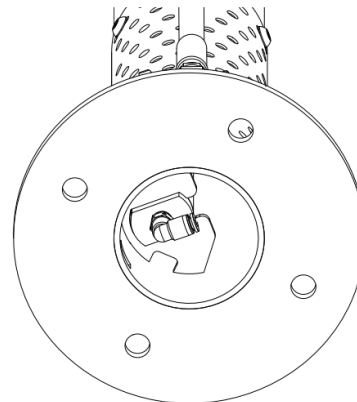

It may be necessary to gain access to the bottom of the main body to align the pump when re-assembling.

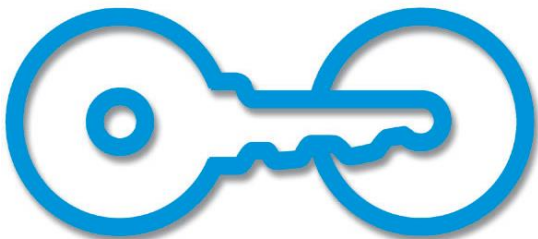

**American Bicycle Security Company**

P.O. Box 7359

Ventura, CA 93006

Ph: (800) 245-3723 or (805) 933-3688

Fax: (805) 933-1865

[www.ameribike.com](http://www.ameribike.com)

Email: [turtle@ameribike.com](mailto:turtle@ameribike.com)



Remove Metal Head™ by turning counter-clockwise. You will need a 3/4" wrench. Replace with new Metal Head and tighten.

