



Ultra Space Saver Squared



The Ultra Space Saver Squared offers high-security, vertical bike parking.

Adjustable sliding arms make it easy for customers to best utilize their space. It also creates flexibility to make sure bike spacing follows city requirements as they evolve. Pipe-cutter resistant squared steel tubing makes the Ultra Space Saver Squared more secure than the original Ultra Space Saver.

The Ultra Space Saver Squared is an easy to install, modular system. It can be made to fit in nearly any space. Options include: wall-mount, floor-mount, and double-sided. Call American Bicycle Security for a FREE custom room layout.

American Bicycle Security Company

P.O. Box 7359

Ventura, CA 93006

Ph: (800) 245-3723 or (805) 933-3688

Fax: (805) 933-1865

www.ameribike.com

Email: turtle@ameribike.com

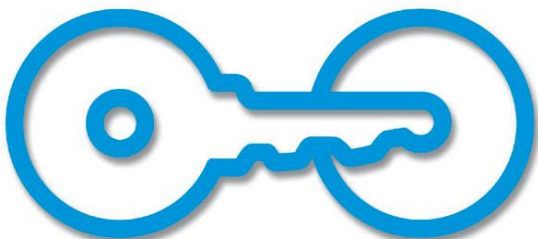

Ultra Space Saver Squared



Height Requirement: 87"

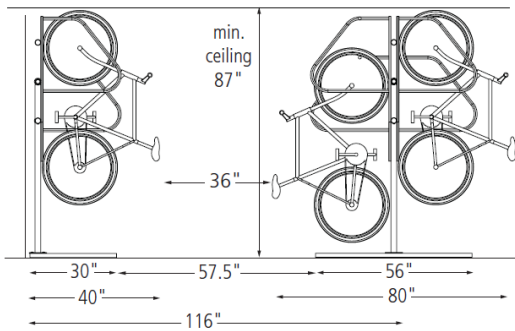
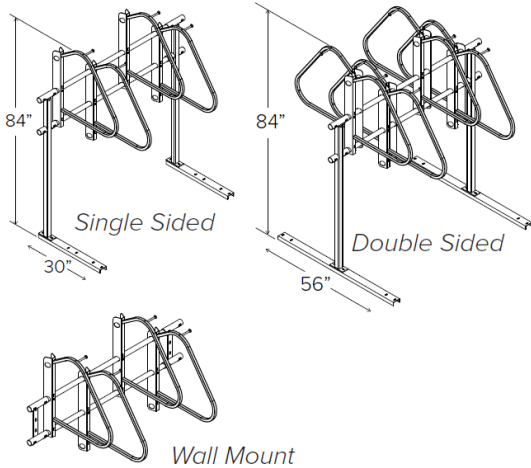

Example of rack in use

Product Ultra Space Saver Squared

Capacity Modular Construction
1 Bike per arm

Materials Hanger is 1" square tube with steel slider head with tamperproof locking bolts.
Upright is 2" square tube.
Feet are AISI C3 x 4.1 galvanized steel channel. Crossbeams are 2" sched. 40 powder coated pipe.

Finishes Standard options: Galvanized Or Powder Coated



RAL 9005	Flat Black	RAL 9003	RAL 2004	RAL 1023	Bright Yellow
RAL 6016	RAL 6018	RAL 6005	RAL 5005	RAL 5015	Purple
RAL 7011	RAL 7042	RAL 9007	RAL 1001	RAL 8014	Bronze
RAL 3003	RAL 3005				

Installation Methods **Floor mounted** Ultra Space Savers have steel channel feet (30" for single sided and 56" for double sided units) which must be anchored to the floor. A **wall mounted** unit which contains special brackets is also available.

Space Use & Setbacks See Diagram

***Let us Help!**

As a free service, American Bicycle Security will provide a complete CAD layout of your space. Just send us the dimensions of your room, being sure to note the location of doors, columns, etc. and let us maximize your bike storage capacity.

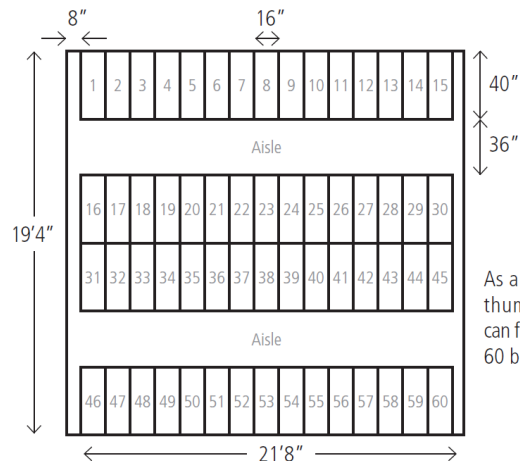

As a general rule of thumb, this space can fit approximately 60 bicycles.

American Bicycle Security Company

P.O. Box 7359

Ventura, CA 93006

Ph: (800) 245-3723 or (805) 933-3688

Fax: (805) 933-1865

www.ameribike.com

Email: turtle@ameribike.com

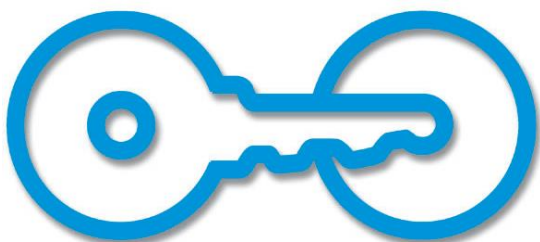

Ultra Space Saver Squared



How to use:

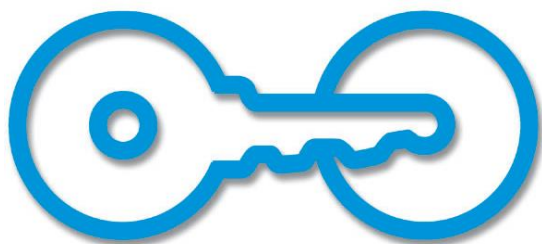
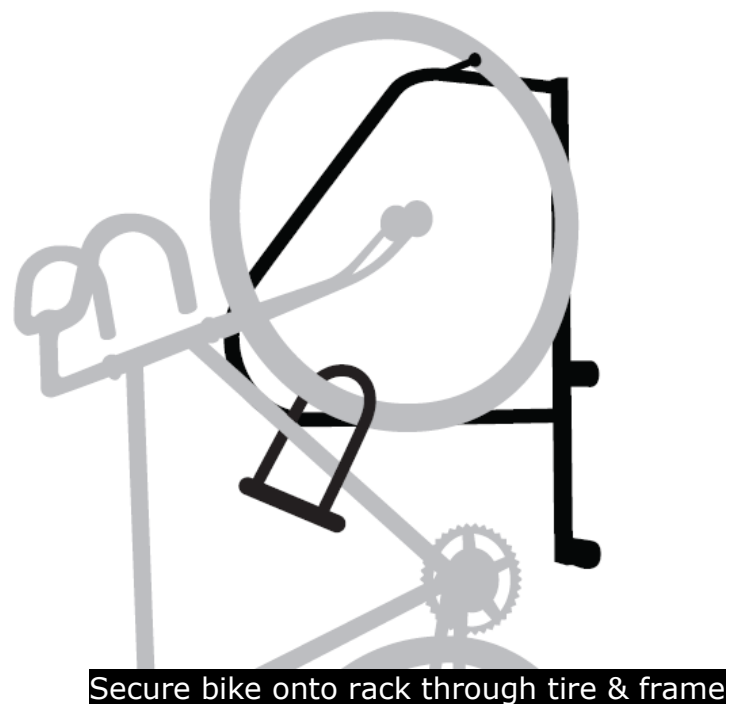
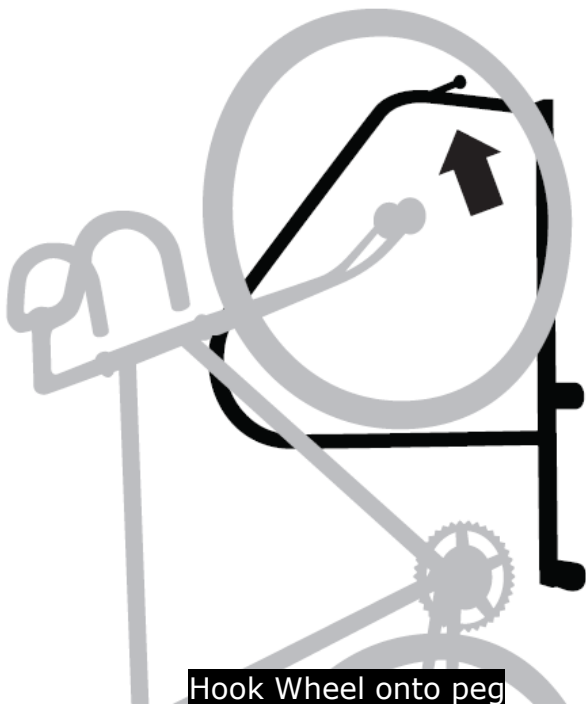
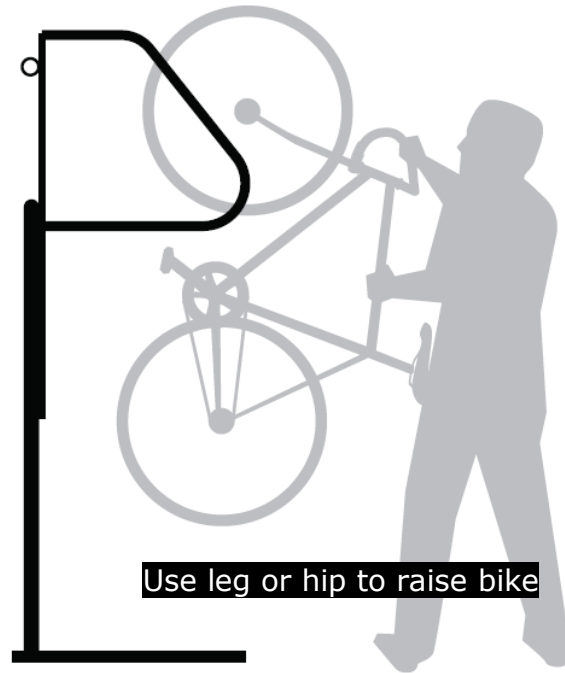
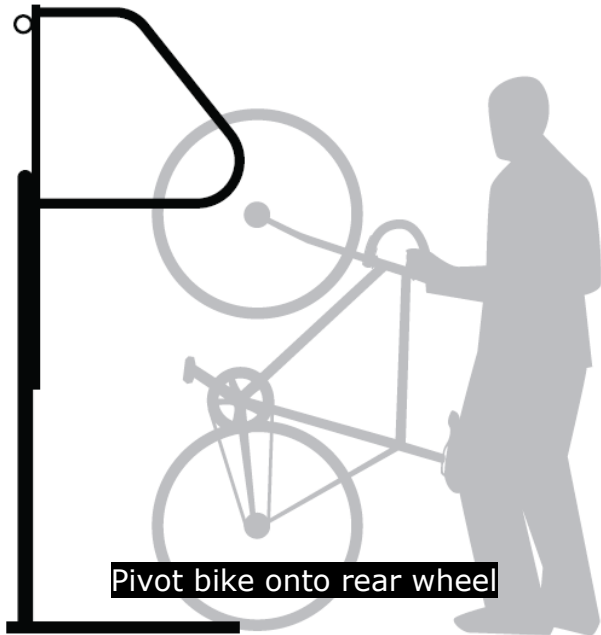

American Bicycle Security Company

P.O. Box 7359

Ventura, CA 93006

Ph: (800) 245-3723 or (805) 933-3688

Fax: (805) 933-1865

www.ameribike.com

Email: turtle@ameribike.com

Ultra Space Saver Squared



Installation

The Ultra Space Saver has several steps for installation. Note that the single and double sided setups and parts are different. Make sure you follow the instructions according to the model you ordered.

Recommended Base materials:

Solid concrete is the best base material for installation. Make sure nothing is underneath the base material that could be damaged by drilling (i.e. post-tension cable). Use the 3.75" wedge anchors that are included to install the rack into the concrete (wall anchors are 3").

Installation:

Sort out the parts to the rack and identify each of them accordingly. The 1" carriage bolts are for assembly of the rack and the 3.75" wedge anchors are for mounting the rack to the floor.

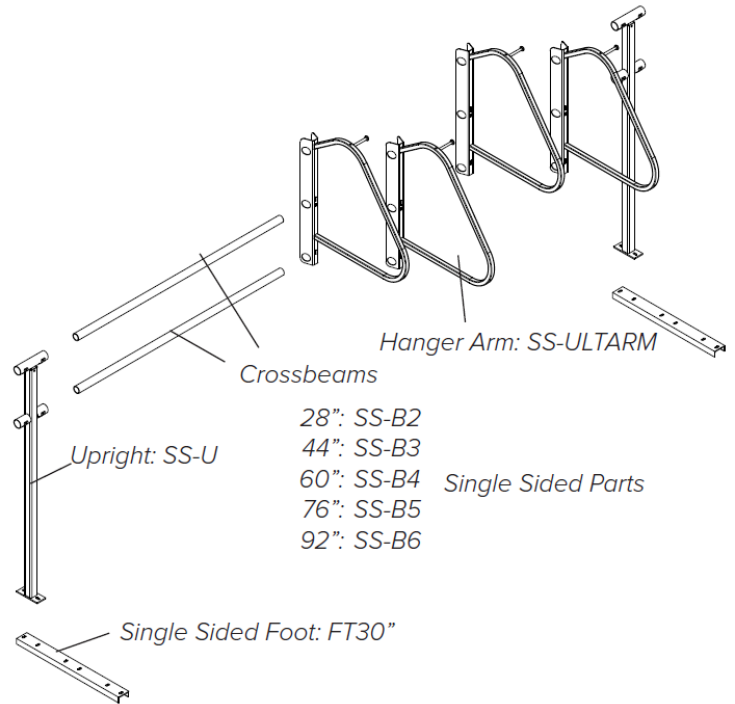

Reading your designed layout

Ultra Space Savers come in varying configurations, making it **very important** that you carefully follow the layout provided when installing the racks. If you do not follow the diagram, you may well end up short of parts. The length of each Ultra Space Saver unit is indicated by a number ranging from B2-B7 in the layout. This number corresponds to the length of crossbeams to be installed. In the example provided below the Ultra Space Saver is to be installed starting with two B4 units, which have 44" crossbeams, followed by a B5, which has 76" crossbeams.

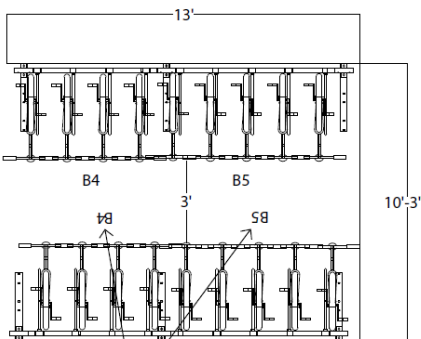

These numbers indicate the number of arms between brackets for each Ultra Space Saver unit to be installed.

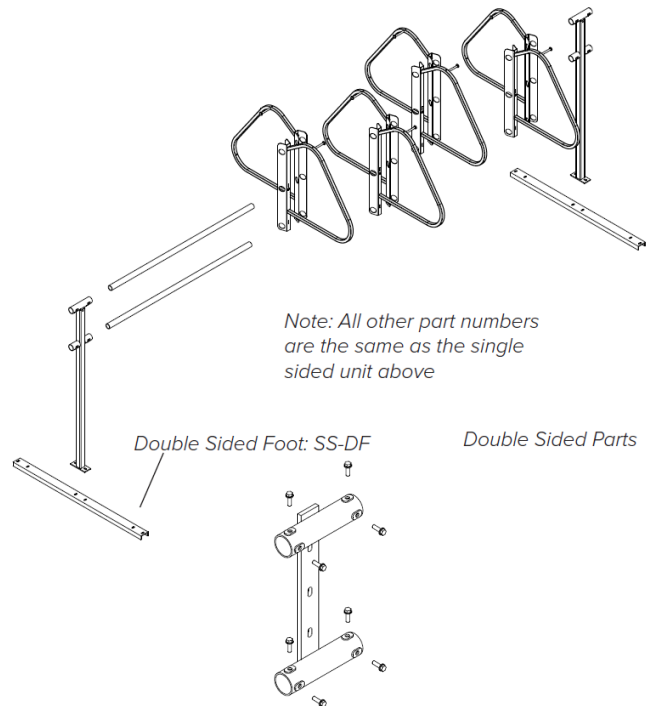

Wall Mounting Bracket

(Wall Mounted Only) - SS-W

American Bicycle Security Company

P.O. Box 7359

Ventura, CA 93006

Ph: (800) 245-3723 or (805) 933-3688

Fax: (805) 933-1865

www.ameribike.com

Email: turtle@ameribike.com

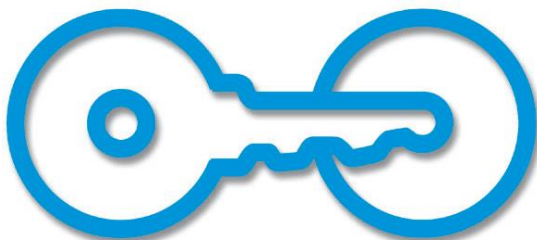

Ultra Space Saver Squared



Wall Mount

*Tools Needed for Wall Mount Installation

- 9/16" Wrench/Socket
- 3/8" or 1/2" Masonry Drill Bit
- (Depending on anchor type)
- Tape Measure
- Drill (Hammer drill recommended)
- Hammer
- Level
- Marker or pencil

Before installing make sure the wall is strong enough to accommodate the rack fully loaded with bikes. Steel stud walls are NOT suitable for installation.



Installation Steps:

1. Lay out parts on the floor where unit is to be installed and be sure you have all necessary parts.
2. On galvanized cross beams, Place a mark three inches from each end. This mark will show you how far to slide the cross beam into the wall bracket.
3. Place first wall bracket on wall where you want to install the bike rack. Bottom of bracket should be at least 50" from ground. Mark holes for drilling. See figure 3.
4. Drill Holes into wall, put the wall bracket back up and insert wall anchors through holes in bracket and set the anchors. For setting the anchors and diameter and depth of holes, follow instructions sent with the anchors. Make sure bracket is level. See figure 4.
5. Thread 3/8" by 3/4" tightening bolts into holes in bracket. Insert crossbeams into bracket. Slide on arms and spacers, make sure arms are staggered. At end of last arm place 3" spacers and install end bracket, making sure cross beams are level. See figure 5
6. If installing more than one set of Ultra Space Saver Squared arms, continue from last installed wall bracket and repeat steps 3-5 above.

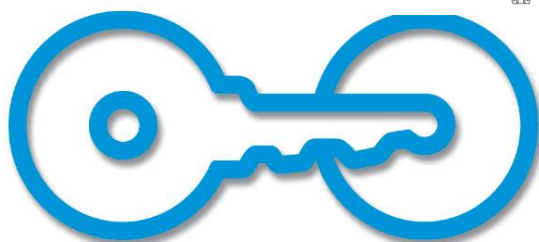
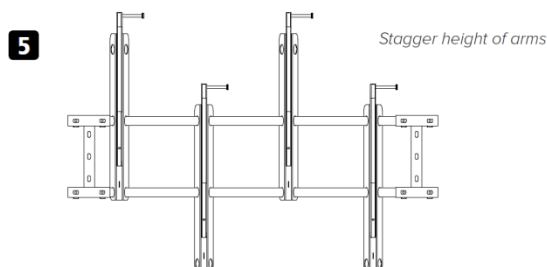
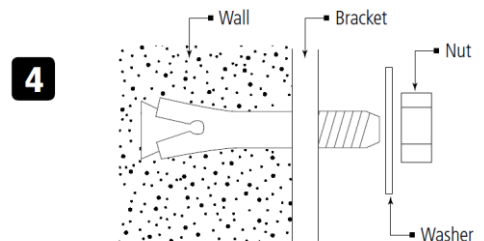
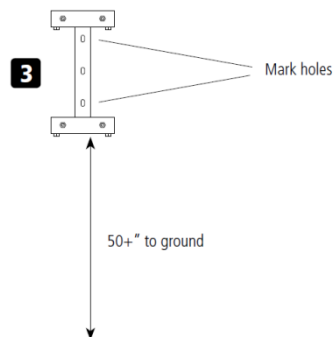

American Bicycle Security Company

P.O. Box 7359

Ventura, CA 93006

Ph: (800) 245-3723 or (805) 933-3688

Fax: (805) 933-1865

www.ameribike.com

Email: turtle@ameribike.com

Ultra Space Saver Squared



Floor Mount

*Tools Needed for Wall Mount Installation

- 9/16" Wrench/Socket
- 3/8" Masonry Drill Bit
- Tape Measure
- Drill (Hammer drill recommended)
- Hammer

1. Measure out space. Attach feet to uprights with carriage bolts provided. See figure 1.
2. Lay assembled uprights with crossbeams attached on their side so crossbeams are facing up. Slide first hanger arm on and tighten set screw to hold in place. See figure 2.
3. Gently slide arms down crossbars but make sure to stagger height of each arm so that the hanger rod is at a different level from its neighboring arms. Tighten set screw. Standard spacing between arms is 16". For double-sided model slide arms on opposite each other. Repeat until the crossbeams are full. See figure 3.
4. Tip rack up and attach the second upright. Tighten bolts. Slide assembled rack into final location. For add-on units repeat steps. See figure 4.
5. Anchor rack to floor with 3.75" wedge anchors. See figure 5

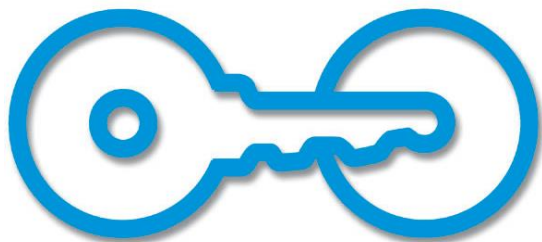
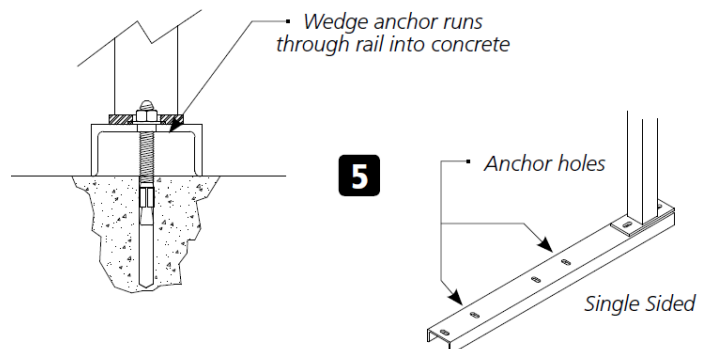
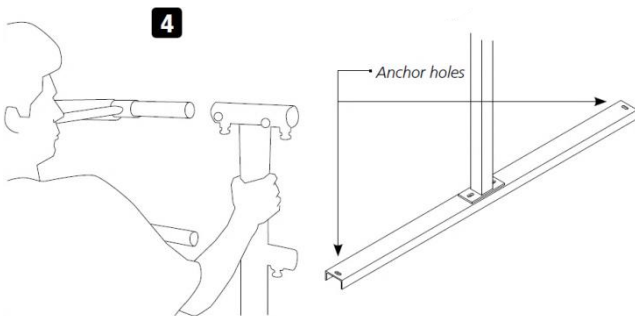
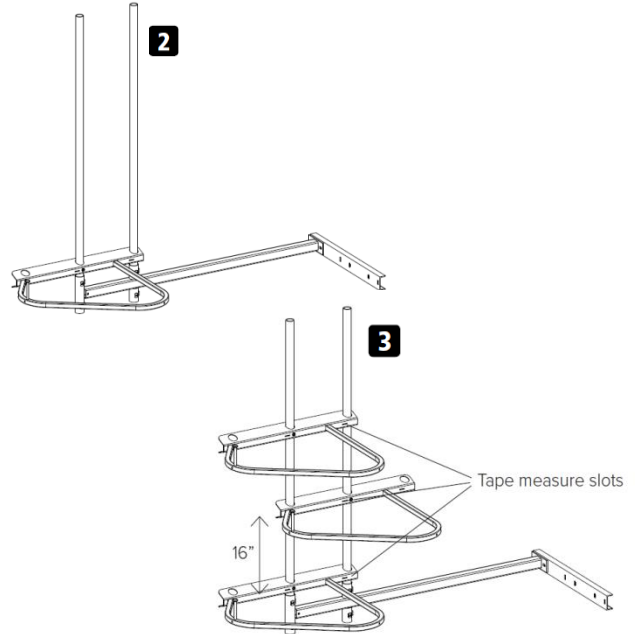
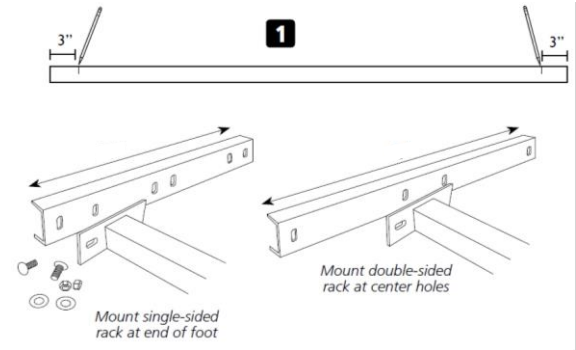

American Bicycle Security Company

P.O. Box 7359

Ventura, CA 93006

Ph: (800) 245-3723 or (805) 933-3688

Fax: (805) 933-1865

www.ameribike.com

Email: turtle@ameribike.com

Ultra Space Saver Squared



Tire Stops (optional)

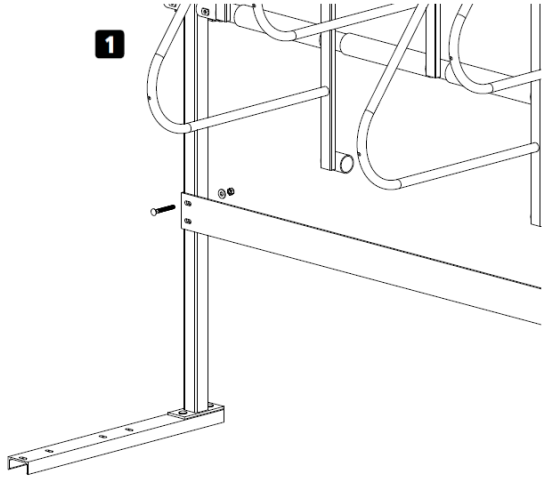

Step 1: Attach tire stop to uprights with supplied hardware.

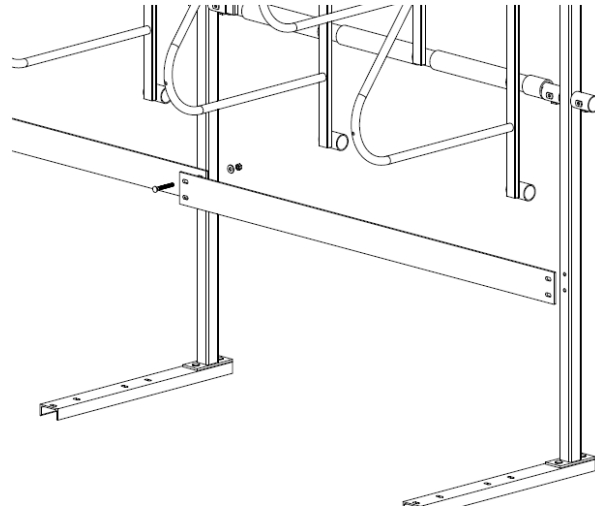

Step 2: Continue attaching tire stops if using a modular.

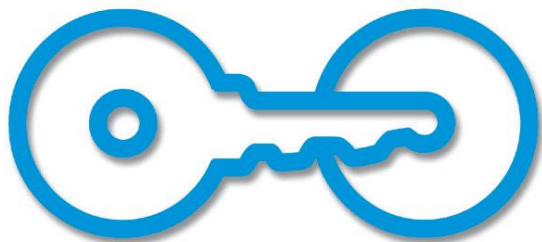
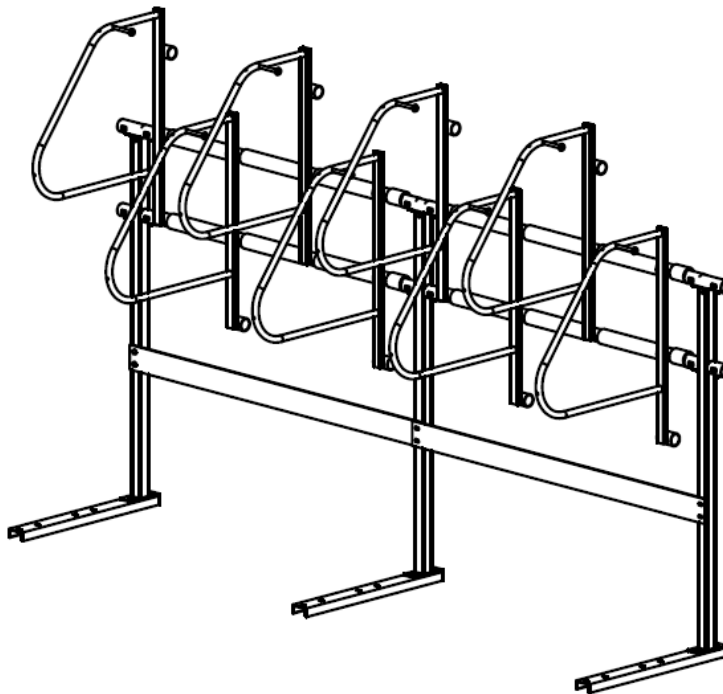

American Bicycle Security Company

P.O. Box 7359

Ventura, CA 93006

Ph: (800) 245-3723 or (805) 933-3688

Fax: (805) 933-1865

www.ameribike.com

Email: turtle@ameribike.com