

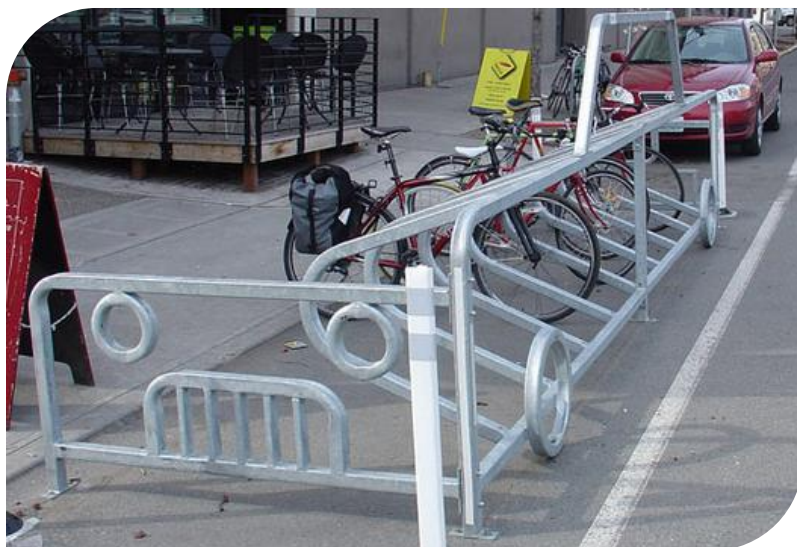

Cycle Stall Elite

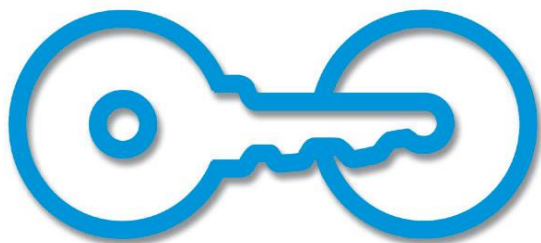

The Cycle Stall turns a standard on-street, car parking stall into protected, bike parking. The Cycle Stall is the first on-street bike parking kit that includes everything needed for the conversion from car to bike parking. The Cycle Stall frame is built from rugged, impact resistant, two inch steel. It provides a physical barrier from traffic while including racks with optimum frame support and security. The Cycle Stall is designed to work in a standard 22' parking stall. Additional sections may be added to extend your on-street bike parking when needed. The Cycle Stall is available in a standard frame or customized with a car or fish design.



American Bicycle Security Company

P.O. Box 7359

Ventura, CA 93006

Ph: (800) 245-3723 or (805) 933-3688

Fax: (805) 933-1865

www.ameribike.com

Email: turtle@ameribike.com

Cycle Stall Elite

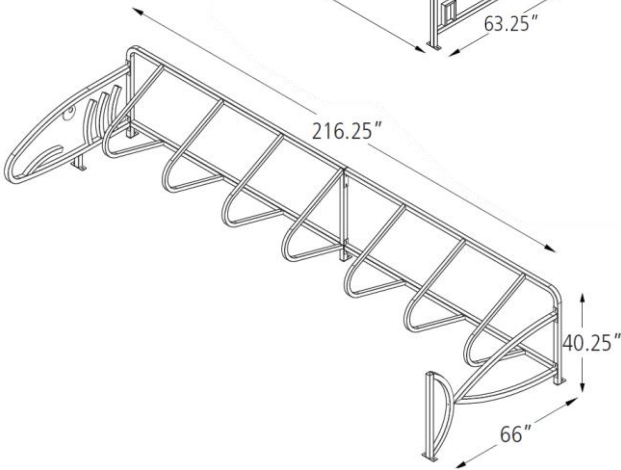
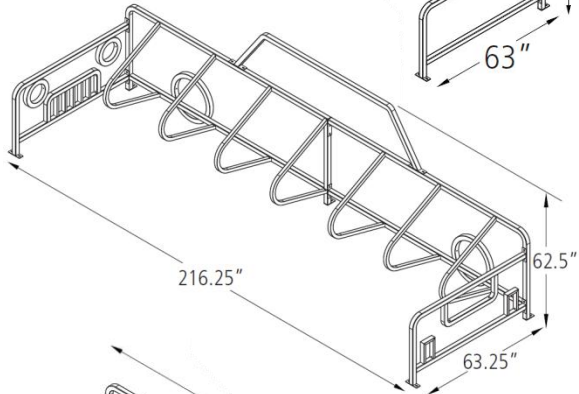
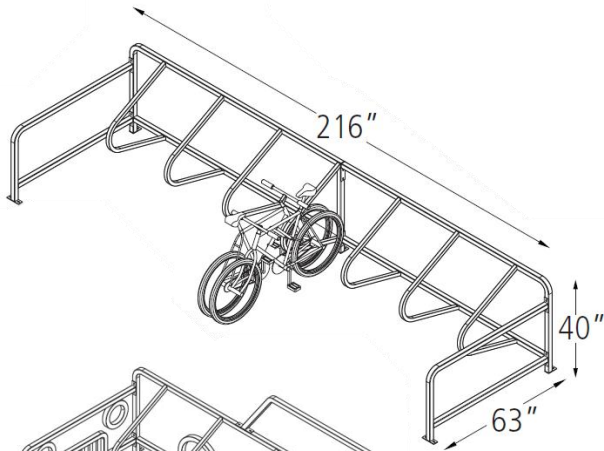

Product Cycle Stall Elite Models:
Square
Car
Fish

Capacity 14 Bikes

Materials Main body 2" x 1/8" square tube
Locking bars 1.5" x 1/8" square tube

Finishes Standard options: Galvanized
Or
Powder Coated



RAL 9005	Flat Black	RAL 9003	RAL 2004	RAL 1023	Bright Yellow
RAL 6016	RAL 6018	RAL 6005	RAL 5005	RAL 5015	Purple
RAL 7011	RAL 7042	RAL 9007	RAL 1001	RAL 8014	Bronze
RAL 3003	RAL 3005				

Installation Methods Surface Mount has five 2" wide feet which should be anchored to the ground with supplied anchors

Space Use & Setbacks The Cycle Stall should be centered length-wise in an on street parking space. The open side of the Cycle Stall should be facing the curb. For width-wise placement, see local guidelines.

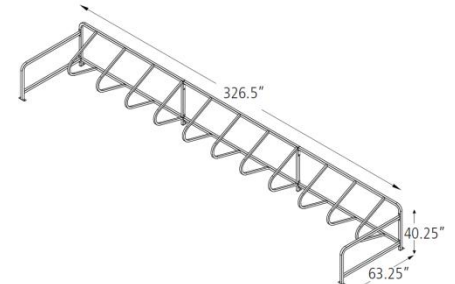
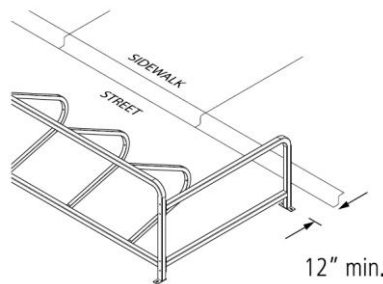

TRAFFIC DELINEATORS



Five 48" tall traffic delineators are included to protect your installation from damage by vehicles.

The delineators are secured to the ground with an epoxy cement and include two bands of reflective tape for greater visibility in low light.

Be sure to check with your local municipal codes and laws for on-street installation regulations.

Due to the Cycle Stall's modular design, additional extender units may be ordered where a higher bike parking capacity is required. Each extension adds parking for 8 more bikes.

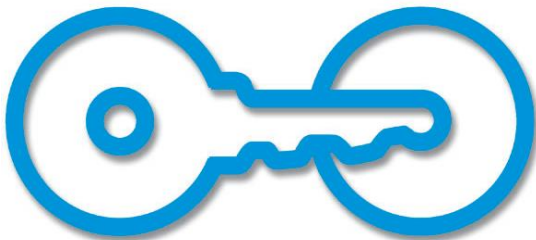

American Bicycle Security Company

P.O. Box 7359

Ventura, CA 93006

Ph: (800) 245-3723 or (805) 933-3688

Fax: (805) 933-1865

www.ameribike.com

Email: turtle@ameribike.com



*Tools Needed for Installation

- Tape Measure
- Marker or Pencil
- Masonry Drill Bit 3/8"
- Drill (Hammer drill recommended)
- Hammer
- Wrench 9/16"

Recommended Base Materials:

A concrete base is the best surface for installation. For installation into asphalt, separate asphalt anchors and instructions will be sent with the rack.

Installation:

Attach the Cycle Stall segments on street with the supplied 3/8" x 2.75" carriage bolts, and move assembled unit into place. 3/8" anchors are shipped with the rack. Be sure nothing is underneath the base material that could be damaged by drilling. Place the rack in the desired location. Use a marker or pencil to outline the holes of the flange onto the base material. Drill the holes in accordance with the specifications shipped with the anchors. Make sure the holes are at least 6" away from any cracks in the base material. Tap in anchors and follow your specific anchor instructions provided with the rack.

Tamper Resistant Fasteners:

The concrete spike is a permanent anchor. The top of the wedge anchor can also be pounded sideways after installation so that it cannot be removed. Other tamper resistant fasteners are also available for purchase. When using the special tamper resistant nuts, always set and first tighten the anchors. Once the rack is installed, replace two nuts from the bracket (opposite sides from each other) with the tamper resistant fastener. **DO NOT OVERTIGHTEN** the tamper resistant nut.

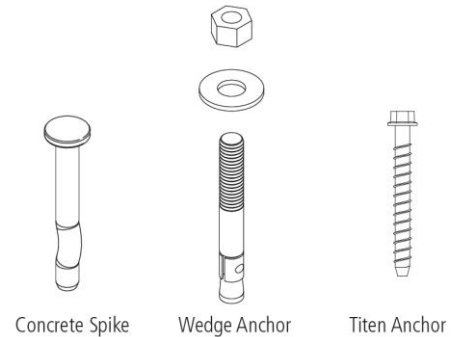
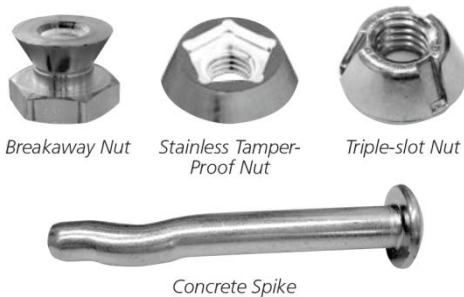

Standard Anchor Types

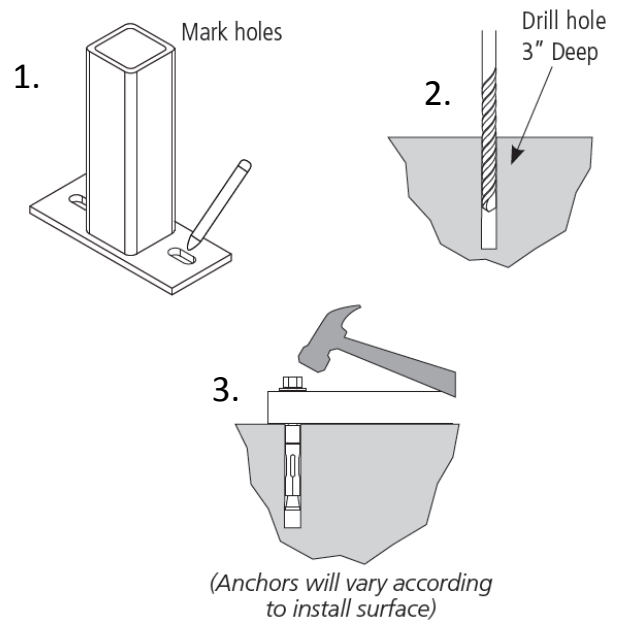

American Bicycle Security Company

P.O. Box 7359
Ventura, CA 93006
Ph: (800) 245-3723 or (805) 933-3688
Fax: (805) 933-1865
www.ameribike.com
Email: turtle@ameribike.com

