

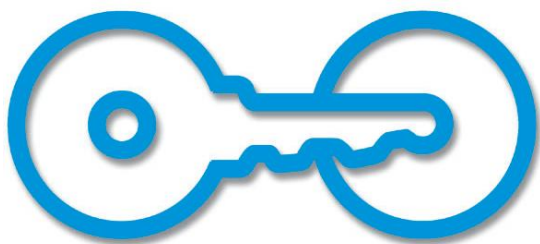

Cycle Stall Basic



One car or ten bikes? Maximize parking for customers at your business with on-street bike parking. The Cycle Stall Basic kit covers the needs of cities and businesses that want to provide an on-street bike corral at a low cost and minimal changes to infrastructure. Designed to fit within a standard size car parking space, the Cycle Stall Basic comes in standard single or double length kits, or can be customized to suit your needs. The bike racks may also be mounted to the rails at 45 degree angles.



American Bicycle Security Company

P.O. Box 7359

Ventura, CA 93006

Ph: (800) 245-3723 or (805) 933-3688

Fax: (805) 933-1865

www.ameribike.com

Email: turtle@ameribike.com

Cycle Stall Basic

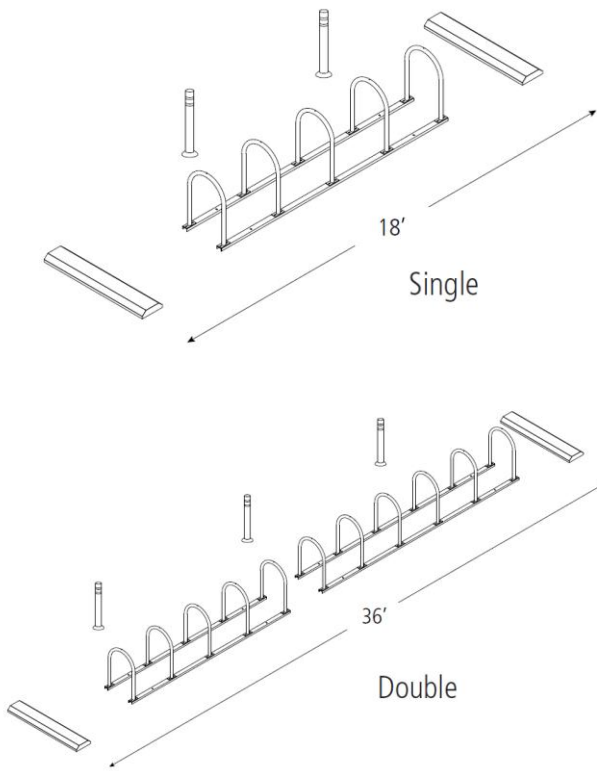

Product Cycle Stall Basic

Capacity Single: 10 Bikes
Double: 22 Bikes

Materials Hoop Racks: 1.5" schedule 40 pipe (1.9" OD)
Wheel Stops: Recycled plastic

Finishes Standard options: Galvanized Rails, Galvanized Racks
Or
Powder Coated Racks



RAL 9005	Flat Black	RAL 9003	RAL 2004	RAL 1023	Bright Yellow
RAL 6016	RAL 6018	RAL 6005	RAL 5005	RAL 5015	Purple
RAL 7011	RAL 7042	RAL 9007	RAL 1001	RAL 8014	Bronze
RAL 3003	RAL 3005				

Racks also available in PVC, Thermoplastic, or Stainless steel (depending on rack)

Installation Methods **Rail mount** - Hoop Racks are mounted to galvanized rails which should be anchored to the ground.

Space Use & Setbacks **Curb Setbacks:**
Minimum: 44"

Traffic Lane Setbacks:
Minimum: 44"

Wheel Stop Setbacks:
Allow minimum of 36" between wheel stops and racks.

Change it up!

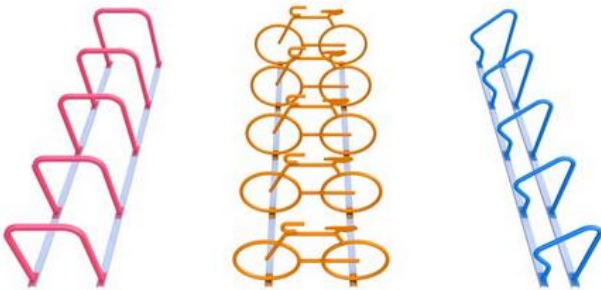

A variety of rack styles may be used to build your bike corral.

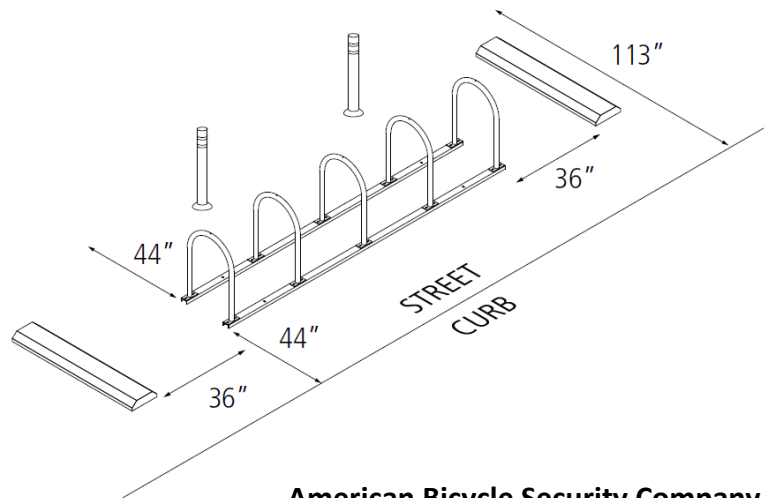

American Bicycle Security Company

P.O. Box 7359

Ventura, CA 93006

Ph: (800) 245-3723 or (805) 933-3688

Fax: (805) 933-1865

www.ameribike.com

Email: turtle@ameribike.com

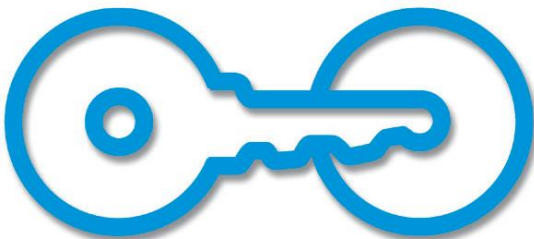



*Tools Needed for Installation

- 9/16" socket set
- (2) 4"x4"x28" (or larger) blocks
- (4) bolts, nuts & washers for each rack.
If using tamper resistant nuts, install two tamper-resistant & two standard nuts with each rack.

Installation steps:

1. Lay out the two channel beams where the rack will be placed. Place both beams on top of the two blocks of wood so that the open part of the channel faces the ground.
2. Place racks on beams so holes in rack flanges line up with beam slots.
3. Put bolts through Hoop Rack flange holes & beams so bolt head faces up. **HAND** tighten the nuts using new flange nuts.
4. Once nuts are on, tip assembled rack over & use a 9/16" socket to tighten nuts. Before tightening nuts, make sure the racks are straight on beams. *If using tamper resistant nuts, use access tool to tighten nuts. **Do not over tighten the tamper resistant nuts.*** Tip rack upright.

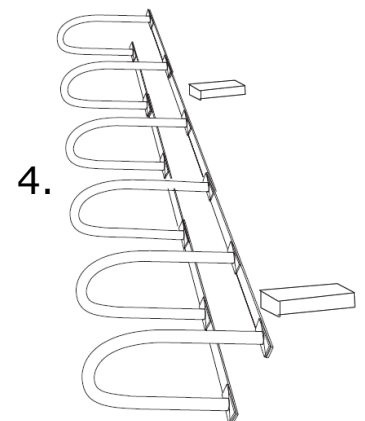
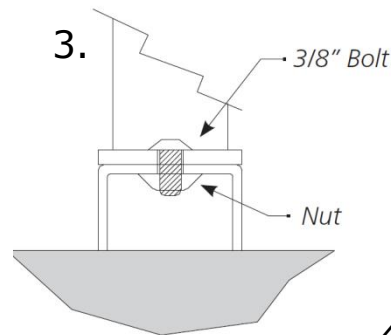
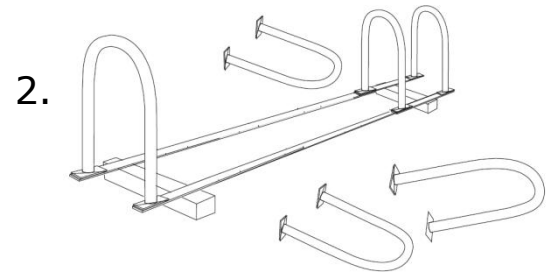
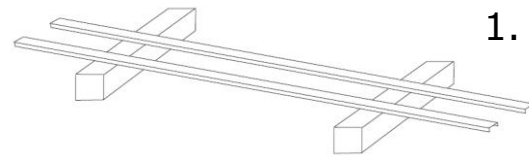

Anchoring Rails:

To anchor the rails to concrete, place 3.75" wedge anchor through holes in the rail into the concrete. Secure with nut.

If anchoring to asphalt surface, use Titen asphalt screws. Place screws through rail holes and turn into the asphalt.

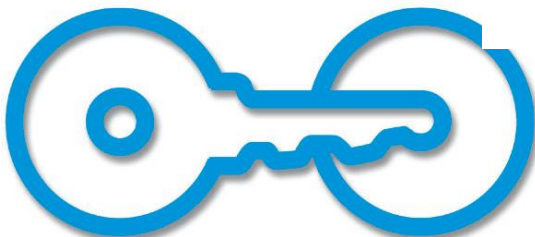
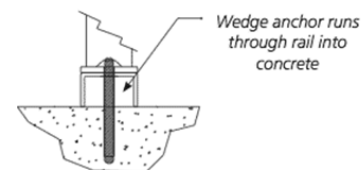
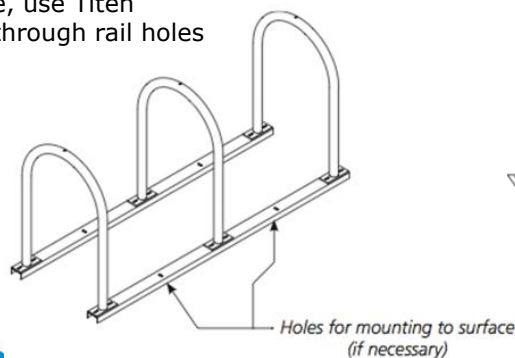

American Bicycle Security Company

P.O. Box 7359

Ventura, CA 93006

Ph: (800) 245-3723 or (805) 933-3688

Fax: (805) 933-1865

www.ameribike.com

Email: turtle@ameribike.com



*Tools Needed for Installation

- Hammer Drill with 3/8" masonry bit
- Socket Wrench 3/8"
- Hammer (if installing into concrete with wedge anchors)

*Site Safety:

Before installation, ensure work site is safe. If necessary, block off the area to prevent vehicle and pedestrian access. Use appropriate signage and work barricades to delineate the work area. Ensure electric power leads and hand tools are safe, in good working condition and only used as per manufacturer's specifications. Remove any potential trip hazards and use appropriate personal safety equipment (safety gloves, safety glasses, safety boots, etc.).

Wheel Stop Installation:

1. Place wheel stop in desired location using setbacks diagram on page 2 as a guide. Mark holes onto surface and remove wheel stop.
2. Drill 3/8" holes through asphalt surface.
3. Line up holes in wheel stops with holes in road surface and use 3/8" socket wrench to secure the provided anchors.

TRAFFIC DELINEATORS

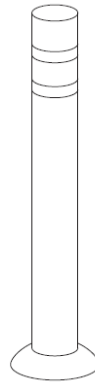

Two 48" tall traffic delineators are included to protect your installation from damage by vehicles. Three delineators are included with the double-sized kit.

The delineators are secured to the ground with an epoxy cement and include two bands of reflective tape for greater visibility in low light.

